

Thermo-mechanical analysis of composite slabs under fire conditions

D. Pantousa & E. Mistakidis

Laboratory of Structural Analysis and Design, Dept. of Civil Engineering, University of Thessaly, Volos, 38334, Greece

ABSTRACT: The paper studies the behavior of composite slabs with corrugated steel sheeting in elevated temperatures. Two structural systems are considered: a simply supported composite slab and a continuous composite slab that consists of two equal spans. Both of them are designed according to the respective Eurocodes for strength and fire resistance. In the sequel sophisticated three-dimensional models of the slabs are developed and they are submitted to coupled-thermo mechanical analysis, which takes into account the various nonlinearities that are present in the physical model (dependence of the thermal and mechanical properties of the material on temperature, nonlinear material behavior, cracking etc). The results are compared with those expected by the procedures of Eurocode 4.

1 INTRODUCTION

Composite slabs made of corrugated steel sheeting are commonly used nowadays for the covering of large spans. With respect to ordinary reinforced concrete slabs, they exhibit a number of advantages, as e.g. the ability for the casting of concrete without additional scaffold structures, ease of construction etc. However, concerning fire resistance, they exhibit a significant drawback with respect to reinforced concrete slabs, due to the fact that the corrugated steel sheeting may be directly exposed to fire and consequently may lose quickly its mechanical properties (stiffness and strength degradation). For this reason, additional reinforcement is usually used in order to ensure that the slab will retain its robustness for the amount of time required by the various fire design codes.

For the modeling of composite slabs, various models have been proposed in the literature. Yu X. et al. (2008) proposed a model of an orthotropic slab in fire, which is developed in the software code Vulcan. In order to obtain the real temperature distribution within the slab, the upper continuous portion of the profile is modeled through layered isoparametric slab elements. In this respect the temperature of each layer of the slab is not necessarily uniform in the horizontal plane and it is assumed that temperature can be varied between different Gauss integration points. A beam element is used to represent a group of ribs of the slab, and the width of this element is an equivalent width calculated from the geometric properties.

In the study of Gillie M. et al. (2001), a finite element analysis of the first Cardington test is carried out. In particular, 3-dimensional shell elements are used to model the behavior of the composite slab, which takes into account material and geometric non-linearity as well as curvature and non-linear thermal gradients. The time-temperature curve that is obtained from the temperature sensor placed 75mm below the top surface of the rib, is used for the thermal loading of the composite slab. This work underlines the effects of thermal expansion during the fire exposure.

A more accurate thermal analysis of composite slabs is performed in Lamont S. et al. (2001), where a finite element adaptive heat transfer program is used. This model takes into account the temperature differential between hot steel metal deck and cold concrete as well as the air gaps that arise between the materials. This problem is modeled using interface elements between the concrete and the steel profile. The parametric analysis indicates that the key factors affecting the predicted temperatures are the heat conduction and the moisture content of concrete.

In this paper a numerical model is used to assist the evaluation of the behavior of composite slabs in elevated temperatures, which is based on the coupling of three-dimensional solid elements that model the concrete with 4-node shell elements that model the steel profile. Reinforcing steel bars are modeled through three-dimensional beam elements. The model takes accurately into account the effects of the increased temperature. The temperatures in the

corrugated steel sheeting and in the mass of the slab are calculated for the standard ISO fire curve. The thermal and structural material properties in elevated temperature are taken into account according to the latest structural codes. The results of the numerical model are compared to those obtained following the provisions of Eurocode 4.

2 NUMERICAL ANALYSIS

2.1 Description of the problem

The goal of this study is the numerical simulation of composite slabs under fire conditions. In order to study the fire performance of composite slabs, two structural systems are considered: a simply supported composite slab having span equal to 3.5m and a continuous composite slab 7m long, which consists of two equal spans.

The dead load G of the slabs is calculated $G=3.97$ kN/m^2 while the live load is Q taken equal to 5 kN/m^2 . In both cases the composite slabs are constructed by a trapezoidal steel profile and concrete and they have the same cross-section properties. The slab has an overall depth of 150mm and the depth of the steel decking is 73mm. The steel decking is a thin walled cold formed profile, made of structural steel FeE320G. The thickness is equal to $t=1$ mm. A normal-weight concrete with calcareous aggregates is used which has a compressive strength of 25Mpa and a tensile strength of 2.9Mpa, at room temperature. The steel reinforcement has a yield stress equal to 500Mpa. All the material properties of steel and concrete are according to EN 1993-1-2 (2003) and EN 1992-1-2 (2002), respectively.

In both cases the slabs are designed to have almost the same load-bearing capacity at room temperature. More specifically, the sagging moment resistance of the simply supported slab is approximately equal to the hogging moment resistance of the continuous slab. Consequently the over-strength factor λ which demonstrates the ratio between the moment resistance and the design moment, is the same for both structural systems, at room temperature.

The design of the continuous slab at room temperature for the ultimate limit state combination ($1.35G+1.5Q$) is performed considering the fact that the load bearing capacity must be almost the same for both structural systems. Taking into account this assumption, first the lower reinforcement is determined assuming a single $\Phi 8$ bar at every rib of the composite slab (i.e. $\Phi 8/187.5\text{mm}$). This reinforcement, is assumed to extend along the total length of the slab. Then, the upper reinforcement is calculated, so that it leads to hogging moment resistance equal to the sagging one. The calculations give an upper reinforcement demand of $\Phi 12/120\text{mm}$. This reinforcement is divided into two groups of reinforce-

ment bars. In the first group the bars are placed every 240mm ($\Phi 12/240$) and extend along the total length of the slab. In the second group, the bars are placed every 240mm ($\Phi 12/240$) and extend from the mid-length of the left span to the mid-length of the right span. This configuration sums to $\Phi 12/120$ over the area of the central support, while the regions near the left and right outer supports remain with $\Phi 12/240$. All the reinforcement bars are assumed to have a cover of concrete of 30mm. Table 1 summarizes the results of the structural design at room temperature, for both cases. The design values of material properties are resulting from the partial safety factors for fire conditions ($\gamma_{M,fi}=1$).

The fire design is based on the loading combination for accidental design situations which is given in EN 1991-1-2 (2002) and it can be simplified to $G+\psi_{1,1} Q$ (Fig. 1). The combination factor $\psi_{1,1}$ is considered here equal to 0.5. For the simply supported system, the fire resistance time is easily calculated according to EN 1994-1-2 (2003), from the properties of the mid-span cross-section. With the data given above, the fire resistance time for the simply supported system results to be 75 mins (R75).

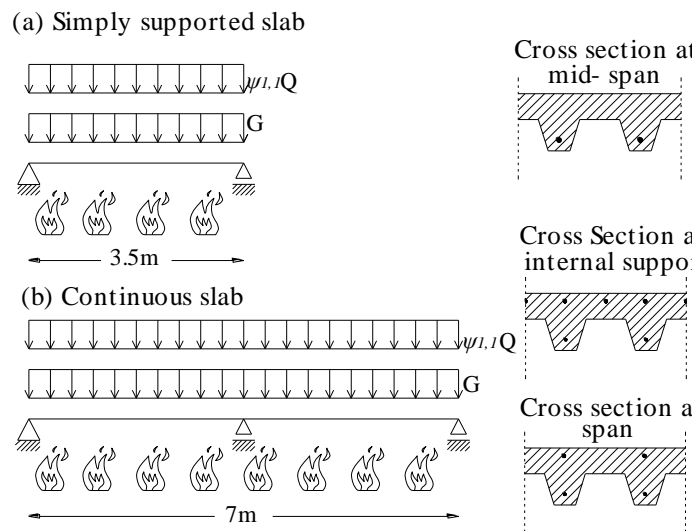

Figure 1. Structural systems and cross sections of composite slabs.

The case of the continuous slab is a little bit more complex, due to the fact that the system is statically indeterminate and some simple calculations are needed in order to find its fire resistance time (Fig.2). In the specific continuous slab studied here, first the moment at the span will reach the resistance moment. This happens at the 96th minute of the ISO fire. After this point, moment redistribution takes place and the moment increases at the internal support. As the fire continues, both the hogging and sagging resistance moments decrease. At a critical time, both the sagging moment and the hogging moment reach to the corresponding resistance values and the slab becomes kinematically unstable. Simple calculations show that this happens at the 145th mi-

nute of the ISO fire, i.e the continuous slab has a fire resistance of R145.

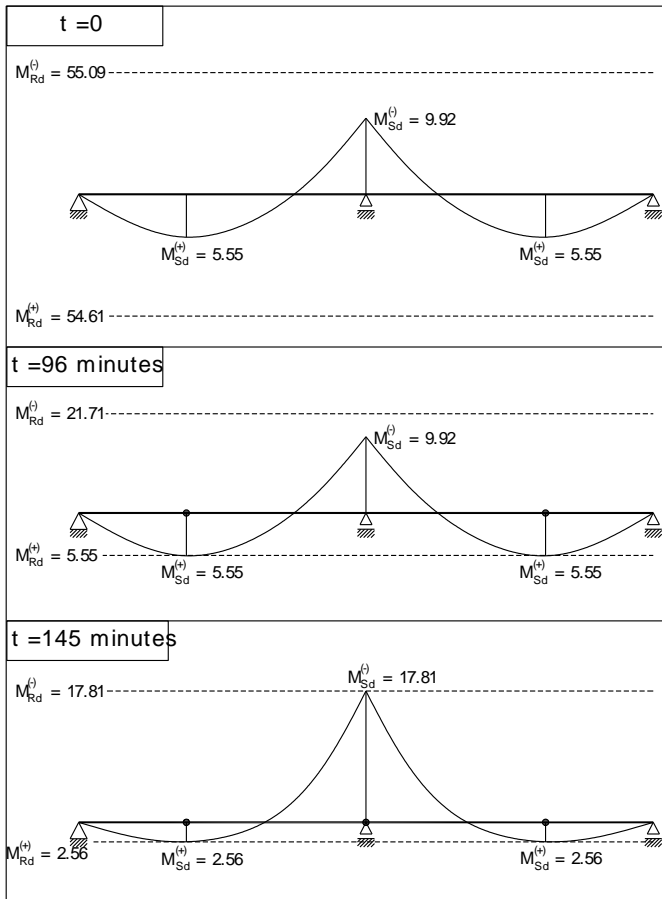

Figure 2. Progressive collapse of the continuous slab in elevated temperatures (moments given in kNm/m).

In this study numerical models are developed in order to obtain both the resistance of the composite slabs in fire exposure and the temperature profile at elevated temperatures. The R criterion will be satisfied if the collapse times exceed the aforementioned failure times.

	$M_{Rd}^{(+)}$ kN·m/m	$M_{Rd}^{(-)}$ kN·m/m	Lower reinf.	Upper reinf.	Over- strength factor λ
Simply supported slab	54.19	-	Φ8/187.5	-	0.363
Continuous slab	55.09	54.61	Φ8/187.5	Φ12/120	0.357

Table 1. Load bearing capacities and amounts of reinforcement.

2.2 Development of the numerical model

The numerical analysis was carried out using the non linear finite element code MARC. Due to the fact that composite slabs are formed using continuous profiled sheeting, it is adequate to simulate a section which is 187.5mm wide (Fig. 3). Moreover, due to the symmetry of this section with respect to the vertical axis, it is adequate to finally model only half of this. For further simplification, as trying to reduce the computational cost which is associated

with the nonlinear three-dimensional modeling, only half of the total span is modelled (1.75m), using the appropriate symmetry boundary conditions. The simplified model and the accurate dimensions of the composite slab are given in Fig. 3.

The advanced models which are developed for the simulation of the composite slabs use three different types of elements. The steel profile is modeled through a four-node shell element while concrete is simulated with three-dimensional solid elements. The nodes of the shell elements are connected to the corresponding nodes of the 3D-solid elements of concrete (Fig. 4). Two-node frame elements are used for modeling the reinforcing bars.

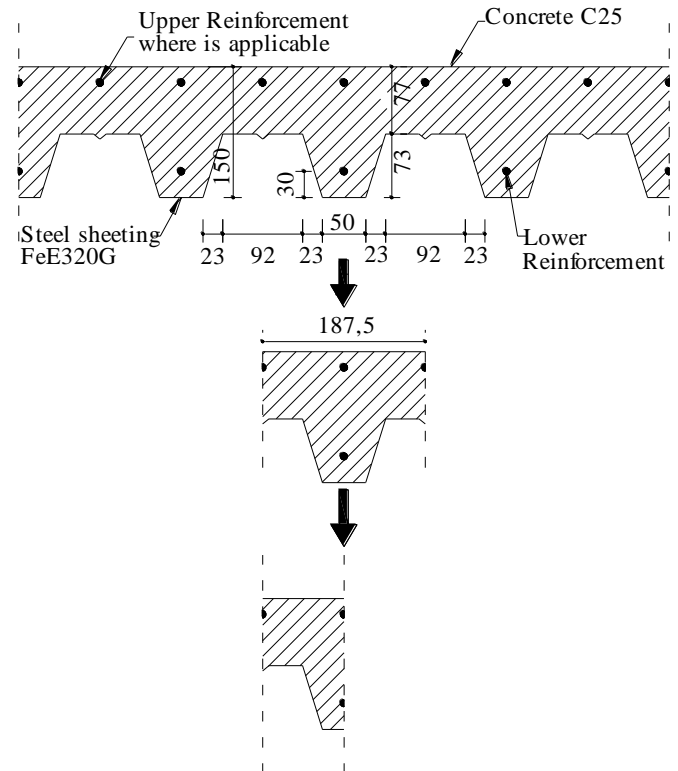

Figure 3. Simplification of the analysis model.

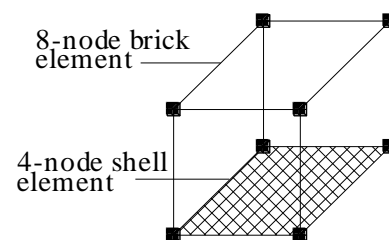

Figure 4. Connection of shell elements with brick elements.

The numerical analysis for the determination of the fire resistance of the composite slab, presents a lot of difficulties. During the fire exposure, the following non-linear phenomena evolve:

- Non-linear material response of both steel and concrete.
- Dependence of all the mechanical-thermal properties of the materials on temperature.

- Possible cracking of concrete due to its low tensile strength.
- Non-linear temperature distribution in the section of the slab.

2.3 Analysis

In order to find numerical solutions to the described problems, the following thermal boundary conditions were taken into account (Fig. 5).

- Along the symmetry boundaries, adiabatic boundary conditions were considered.
- On the upper side of the composite slab (ambient air side), a solid-fluid boundary condition was considered.

In this case, where solid boundaries are in contact with moving fluids, the following boundary condition can be written:

$$-k_n \frac{\partial T}{\partial n} = h_f (T_f - T_s) = h_f \Delta T \quad (1)$$

where h_f is the heat transfer coefficient and ΔT is the temperature difference between the fluid and the solid boundary surface. In this case T_f is the fluid ambient temperature (assumed as known) and T_s is the temperature of the solid surface, which is not a priori known, but is calculated as a result of the solution process. For cases which are of interest in structural analysis problems, both convective and radiation heat exchange takes place and (1) can be written in the form

$$-k_n \frac{\partial T}{\partial n} = \alpha (T_f - T_s)^\beta + \Phi \varepsilon_r \sigma (T_f^4 - T_s^4) \quad (2)$$

where, α and β are coefficients that depend on the side of the structural elements (fire side or ambient temperature air side), Φ is the configuration or view factor, ε_r is the resultant emissivity (which depends on the fluid and solid emissivities) and σ is the Stefan-Boltzmann constant. The first part of the r.h.s. of equation (2) is known as the convective term whereas the second one is known as the radiative term. The term ε_r can be evaluated by the simple formula

$$\varepsilon_r = \varepsilon_f \times \varepsilon_m \quad (3)$$

where ε_r is the emissivity of fire (usually taken equal to 1.0) and ε_s is the emissivity of the structural material. For the upper side of the slab, in equation (2) the parameters were taken as $\alpha=2.2$ and $\beta=1/4$ according to Wang Y.C (2002). The second term of the r.h.s of (2) was ignored.

- On the lower side of the composite slab (fire side), solid-fluid boundary conditions were also considered. The parameters of equation (2) were taken as $\alpha=1.0$ and $\beta=1/3$ according to Wang Y.C (2002). In the second term of the r.h.s of (2)

the emissivity of fire ε_f and the emissivity of construction material ε_m (in this case the corrugated steel sheeting) are considered according to EN 1991-1-2 (2002). The parameters were taken as $\varepsilon_f = 1.0$ and $\varepsilon_m = 0.7$ respectively. The view factor of the lower flange of the profiled steel sheeting was taken equal to $\Phi_{l.f.} = 1.0$. The view factors of the web and of the upper flange of the steel sheeting were calculated following the approach first developed in Wickström U. & Sterner E. (1990) and adopted also by EN 1994-1-2 (2003). The calculations for the specific profile used here give $\Phi_{web} = 0.510$ and $\Phi_{u.f.} = 0.647$ for the web and the upper flange respectively.

The behavior of the composite slab in elevated temperatures is modeled through combined thermal-mechanical analysis. In such a case, the temperature increase contributes to the deformation of the slab through thermal strains and influences the properties of the materials. Actually, a heat transfer analysis is first performed which is followed by a stress analysis.

In this case study the composite slabs are exposed to the standard ISO 834 fire curve for 180 minutes and the problem is simulated through transient heat transfer under constant imposed load. The temperature distribution is assumed to be constant along the length of the slab. The initial temperature for the composite slab is taken equal to 20°C.

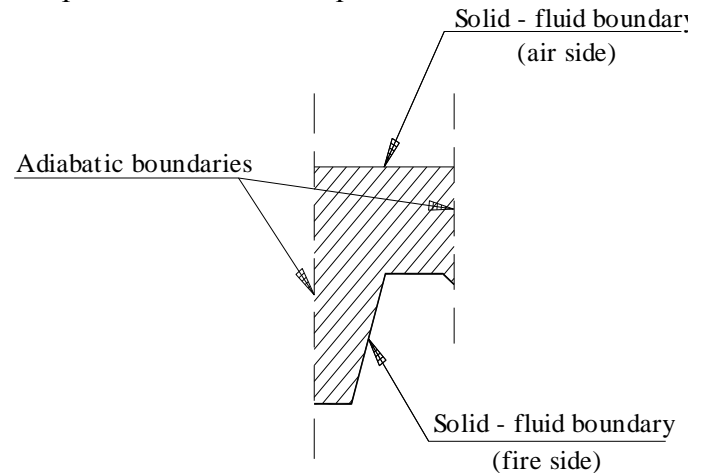

Figure 5. The thermal boundary conditions.

3 RESULTS OF THE NUMERICAL ANALYSIS

3.1 Results of the heat transfer analysis

Figure 6 provides the temperatures at characteristic points for the slab cross-section. It is noticed that the maximum temperatures that are calculated for the lower flange are close to the corresponding values of the standard fire curve. The temperature at points F and G is quite lower due to the reduced incident thermal radiation on the web and the upper flange. As the distance from the steel decking is increasing, the temperature is decreasing and the minimum values are calculated for the upper part of the slab.

According to EN 1994-1-2 (2003) the decisive fire resistance time with respect to the maximum temperature rise, is calculated equal to 70 mins. The temperature of points E, D at the upper side of the concrete slab does not exceed the value of 180°C for the time of 70 minutes and this indicates that the slab satisfies the “I” criterion for thermal insulation.

The temperature distribution that is illustrated in Fig. 7 depicts accurately the isotherms of the cross section. The differentiation of the temperature in horizontal planes is due to the presence of the ribs. The developed temperature pattern is absolutely similar with the one that is indicated in Figure D.3.2.a on EN 1994-1-2 (2003). The temperature of the steel decking after the 20th minute of the analysis (points A, H, F, G) is very high, verifying that it does not contribute significantly in the resistance of the composite slab.

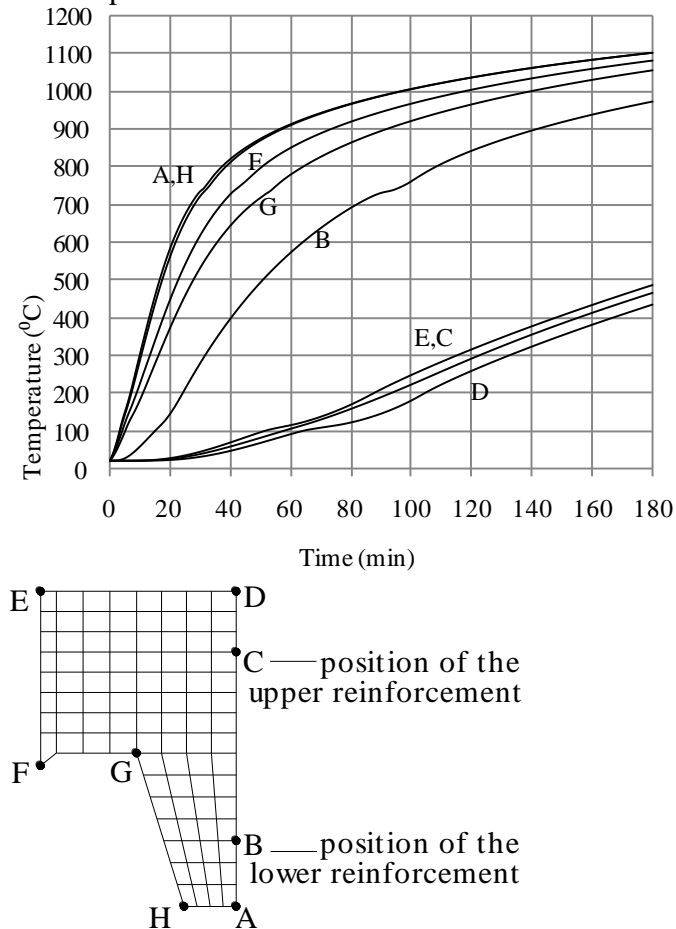

Figure 6. Variation of the temperature in characteristic cross-section points with time.

Table 2 gives the comparison between the numerically obtained results for the temperatures of the various parts of the profiled steel sheeting and for the temperatures of the steel lower reinforcement, with respect to those obtained by applying the recommendations of Eurocode 4 for the same problem. It is noticed that the values of temperature which are resulting from the heat transfer analysis for the steel reinforcement are almost the same, compared with those obtained by Eurocode 4. However, significant differences are observed for the temperatures of the

steel sheeting, indicating that Eurocode 4 is rather conservative in this respect.

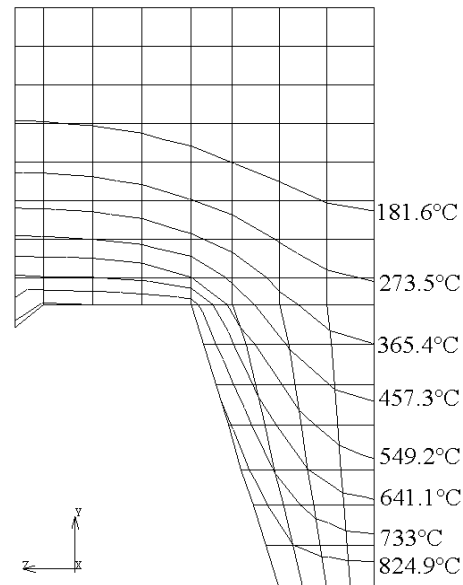

Figure 7. Temperature distribution in the slab cross-section at 60 minutes.

		Mean temperature in the numerical model	Eurocode 4 procedure
60 minutes	Lower Flange	914.0	870.1
	Web	846.4	775.1
	Upper Flange	818.5	694.4
	Lower Reinf.	573.3	571.4
90 minutes	Lower Flange	989.9	965.2
	Web	947.8	906.1
	Upper Flange	922.4	840.1
	Lower Reinf.	732.0	743.5
120 minutes	Lower Flange	1038.7	1021.6
	Web	1008.2	977.8
	Upper Flange	986.5	924.3
	Lower Reinf.	843.9	844.7

Table 2. Comparison of numerically obtained temperatures in the composite slab with those obtained applying the recommendations of Eurocode 4.

3.2 Results of the mechanical analysis

The curves of Fig. 8 give the evolution of the maximum vertical displacement with respect to time.

Considering the case of the simply supported composite slab, the failure occurs at 70 mins. The response of the continuous composite slab is completely different and it finally fails at the 154th minute. When collapse occurs, significant deformations at the span are observed, in both cases. The difference in the response lies mainly on the moment redistribution that takes place during the fire exposure in the case of the continuous slab.

In both cases the contribution of the profiled steel sheeting in the resistance of the composite slab is quite low when the temperature increases significantly, since it loses very quickly its strength. More-

over, it is obvious that the contribution of steel reinforcement is significant to the fire performance of the composite slabs, especially in the case of the simply supported structural system.

The simply supported slab is designed as it is mentioned above, according to Eurocode 4, to have a load bearing capacity during fire exposure for 75mins. However, according to the numerical analysis, the fire resistance time as it is indicated in Fig. 8, is 70 minutes. The difference is not considerable and can be attributed to the fact that the temperature values that are proposed by the Eurocode 4 for the steel sheeting are lower compared with the relevant values that result from the thermal analysis. Finally, the slab fails due to excessive deformation at the mid-span.

As explained above, the continuous slab was found to have fire resistance for 145 mins according to Eurocode 4. The results of the numerical analysis indicate that the failure occurs at the 154nd minute which is very close to the time obtained by means of advanced numerical analysis (145 mins). The difference is reasonable and can be attributed to the assumptions that are adopted by the simplified calculation method.

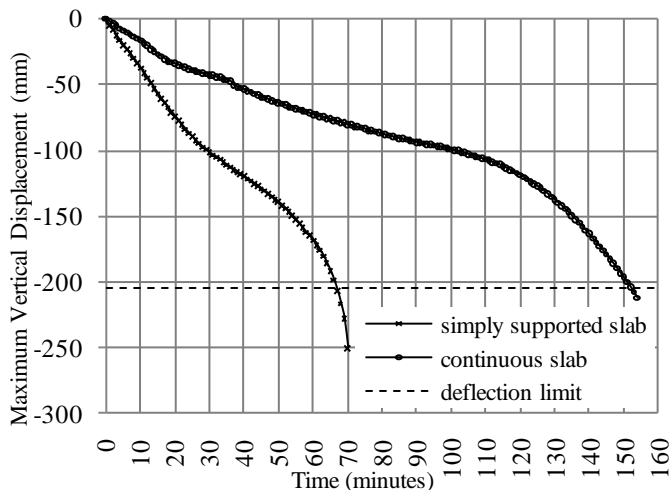

Figure 8. Development of the maximum vertical displacement with time.

It is noticed that in both cases the values of the maximum vertical deflections of the composite slabs are significantly increased in elevated temperatures. In the case of the simply supported slab the failure displacement is equal to 250mm when the temperature is 968°C. In the case of the continuous slab, the maximum vertical deflection reaches the value of 210mm when the corresponding temperature is equal to 1086°C. In practice, deflection limits are imposed in order to avoid the excessive deformation (Purkiss J.A. 2007). The limitations that are used in the standard fire tests is $\delta_{max} = L/30$ for all structural members. Specifically for the flexural members the limit value that is used is $\delta_{max} = L^2/400d$, where d is the depth of the section and L is the length of the span. Comparing the results of these analyses with

the proposed limits, in the case of the simply supported slab the limit deflection $\delta_{max} = L^2/400d = 204\text{mm}$ occurs around the 67th minute, while the continuous slab reaches the limit deflection approximately at the 152th minute.

4 CONCLUSIONS

The paper presents the accurate thermo-mechanical modeling of the behavior of a simply supported and of a continuous two-span slab which are submitted to elevated temperatures, according to the standard ISO fire curve. The slabs are designed for strength and for fire resistance according to the provisions of Eurocode 4. The numerical models are based on combination of three dimensional finite elements for the concrete, shell elements for the profiled steel sheeting and frame elements for the steel reinforcement. All the necessary mechanical and thermal boundary conditions are taken into account and symmetry procedures are applied in order to reduce the dimension of the problem. The analysis results lead to a quite good agreement with Eurocode 4 for the temperatures of the steel reinforcement and to some differences for the temperatures of the steel sheeting. Moreover, the maximum periods of time that each slab is capable of bearing the applied load, as calculated from the numerical procedure, present minor discrepancies with those calculated by means of simple methodologies.

AKNOWLEDGMENTS

This research has been co-financed by the European Union (European Social Fund – ESF) and Greek national funds through the Operational Program "Education and Lifelong Learning" of the National Strategic Reference Framework (NSRF) - Research Funding Program: Heracleitus II. Investing in knowledge society through the European Social Fund.

REFERENCES

- EN 1991-1-2. European Committee for Standardization, 2002. *Eurocode 1. General actions-Actions on structures exposed to fire – Part 1-2. General actions-Actions on structures exposed to fire.*
- EN 1992-1-2. European Committee for Standardization, 2002. *Eurocode 2. Design of concrete structures – Part 1-2. General rules – structural fire design.*
- EN 1993-1-2. European Committee for Standardization, 2003. *Eurocode 3. Design of steel structures – Part 1-2. General rules – structural fire design.*
- EN 1994-1-2. European Committee for Standardization, 2003. *Eurocode 4. Design of composite steel and concrete structures. Part 1-2. General rules – Structural fire design.*

- Gillie M. et al. 2001. A structural analysis of the first Cardington test *Journal of Constructional Steel Research* 57: 581-601.
- Purkiss J.A. 2007. *Fire safety Engineering – Design of structures*. Oxford: Butterworth - Heinemann
- Lamont S. et al. 2001. Heat transfer analysis of the composite slab in the Cardington frame fire tests. *Fire Safety Journal* 36: 815-839
- Wickström U. & Sterner E. 1990. TASEF. Temperature analysis of structures exposed to fire-user's manual, *Swedish National Testing Institute, SP report 05*.
- Yu X. et al. 2008. Nonlinear analysis of orthotropic slabs in fire. *Engineering Structures* 30: 67-80.
- Wang Y.C. 2002. *Steel and composite structures: behavior and design for fire safety*. London: Spon Press.